

Y099PIN



01

DIN 99 - L ? N ?? - ??? ?? ???? ???? ???? ??

Fixed clamping levers



??:
?? ???? ???? ???? ???? (AISI 303).

?? ??:
?????? ???? ??

??:
???? ??

?:
?? INM:
???? ???? ???? (???? ?? 6H).

?? IND:
???? ???? ???? (???? ?? 7H).

?? ???? ??:
??

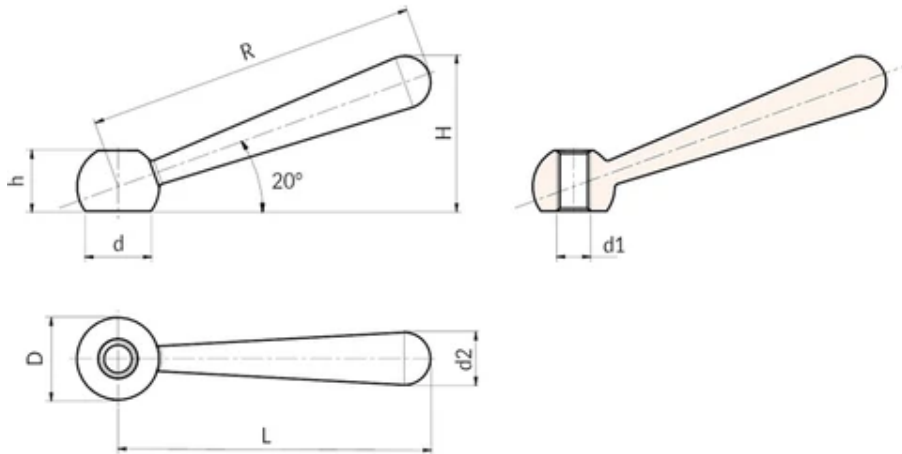

?? Y099 INM - ?? ???? ???? N ???

??	art.	R	L	D	d	d2	h	H	d1 6H	??(g)
Y099063.0002	Y099063.INM08PIN	63	60	16	12.5	10	12	30	M8	36

??	art.	R	L	D	d	d2	h	H	d1 6H	??(g)
Y099080.0002	Y099080.INM10PIN	80	76	20	16	13	14.5	38	M10	74
Y099100.0002	Y099100.INM12PIN	100	95	25	20	16	18.5	47	M12	141
Y099125.0002	Y099125.INM16PIN	125	119	32	25	20	24	59.5	M16	278
Y099160.0002	Y099160.INM20PIN	160	152	40	31	25	30	75.5	M20	564

?? Y099 IND - ????

??	art.	R	L	D	d	d2	h	H	d1 H7	??(g)
Y099063.0001	Y099063.IND08PIN	63	60	16	12.5	10	12	30	08	36
Y099080.0001	Y099080.IND10PIN	80	76	20	16	13	14.5	38	10	74
Y099100.0001	Y099100.IND12PIN	100	95	25	20	16	18.5	47	12	141
Y099125.0001	Y099125.IND16PIN	125	119	32	25	20	24	59.5	16	278
Y099160.0001	Y099160.IND20PIN	160	152	40	31	25	30	75.5	20	564