

S119



19

패널 TP용 암 커넥터 (인버터 전용)

퀵 커플링 DINS

재질:

(2-3) 페놀 수지.
오일과 그리스에 강함.
고온에 강하다.

표면 처리:

광택.

색상:

검정 (RAL 9011).

인서트:

- (1) 암 커넥터 UNI가 있는 황동 삽입물.
- (4) 흑색산화 처리된 강철 골형 와셔 DIN 137.
- (5) 황색 부동태 처리된 강철 나사산 육각형 링 너트.
- (6) 흑색산화 처리된 강철 분할 와셔 UNI 1751.
- (7) 황색 부동태 처리된 강철 와셔.
- (8) 노란색 부동태 처리된 육각 머리 나사 DIN933/UNI 5739.

특별 요청 사항:

없음.



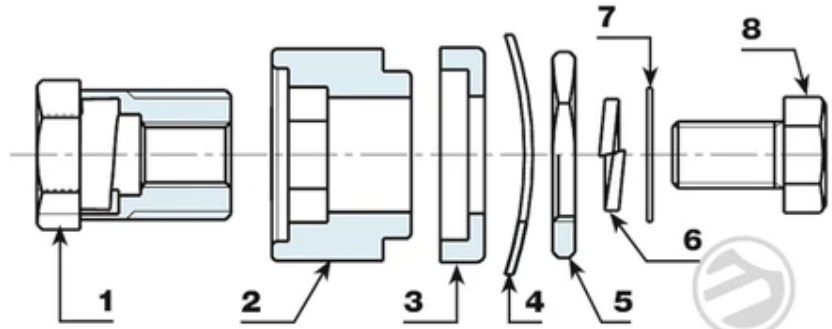
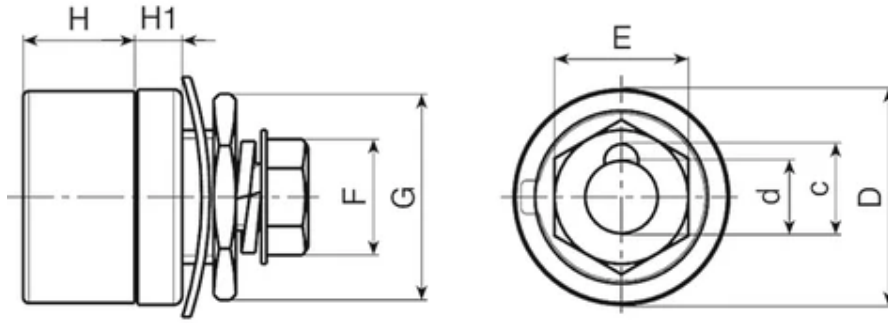

© Copyright
Boteco srl Unipersonale

코드	art.	D	H	H1	d	c	E	F	G	무게(g)	Amp. Max
S119.0001	S119.F3550	38	20	8	13	16	21	17	27	121	200